

Aluminium profiles

Overview

PP profiles Panel profiles

2-4



PP 50



PP 100

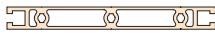

PP 150



PP 200

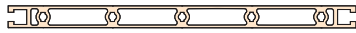

PP 250



PP 50L

PU profiles Universal profiles

2-5

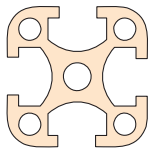

PU 25

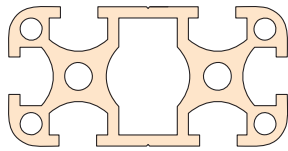

PU 50

PT profiles T-slot plates

2-6



PT 25

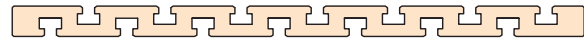

PT 50

RE profiles Right angle profiles

2-8

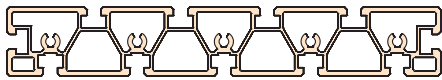

RE 40

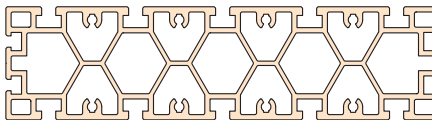

RE 65

PL profiles Light frame profiles

2-10

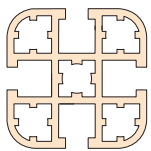

PL 40

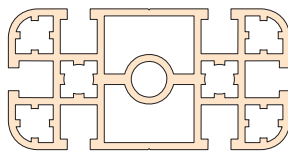

PL 80

PS profiles Stand profiles

2-11



PS 50

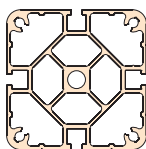

PS 80

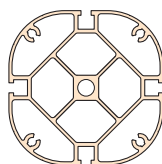

PS 100

Aluminium profiles

Overview

■ AT	Workbenches	2-13
■	Accessories	2-14
■	Profile connections	2-16
■	Profile snaplock connections	2-17

Panel profiles

PP profiles



Features

- For fast and easy erection of frames, benches and racks
- Aluminium, naturally anodised
- Produced to DIN EN 12020-2
- Easy, very strong under load
- **Top edge particularly suitable as a load-bearing cladding, also takes very high loads**
- The drilled holes and PS profile socket head screws of our profile linkages offer extremely rigid connections, resistant to tension, distortion and bending.
- Profile cutting to order
- Extensive range of accessories (see page 2-14)

Technical specification

	PP 50 L	PP 50	PP 100	PP 150	PP 200	PP 250
Dimensions (W × H)	50 x 50 mm	50 x 16 mm	100 x 16 mm	150 x 16 mm	200 x 16 mm	250 x 16 mm
Length	up to 3 metres (special lengths upon request)					
Weight	approx. 1.7 kg/m	approx. 1.1 kg/m	approx. 1.9 kg/m	approx. 2.6 kg/m	approx. 3.4 kg/m	approx. 4.1 kg/m
	2 cavity inserts Ø 5.5 mm für M6 screw	1 cavity insert Ø 5.5 mm für M6 screw	2 cavity inserts Ø 5.5 mm for M6 screw in 50 mm raster	3 cavity inserts Ø 5.5 mm for M6 screw in 50 mm raster	4 cavity inserts Ø 5.5 mm for M6 screw in 50 mm raster	5 cavity inserts Ø 5.5 mm for M6 screw in 50 mm raster
Moment of inertia I_x	13.25 cm ⁴	8.13 cm ⁴	67.27 cm ⁴	213.92 cm ⁴	482.77 cm ⁴	908.52 cm ⁴
Moment of inertia I_y	13.25 cm ⁴	1.37 cm ⁴	2.46 cm ⁴	3.55 cm ⁴	4.64 cm ⁴	5.74 cm ⁴
Moment of resistance W_x	4.39 cm ³	3.25 cm ³	13.45 cm ³	28.52 cm ³	48.27 cm ³	72.68 cm ³
Moment of resistance W_y	4.39 cm ³	1.71 cm ³	3.08 cm ³	4.44 cm ³	5.80 cm ³	7.17 cm ³

Ordering data

Part no. for L=1000 mm	201 045 1000	201 040 1000	201 041 1000	201 042 1000	201 043 1000	201 009 1000
Part no. for L=3000 mm	201 045 3000	201 040 3000	201 041 3000	201 042 3000	201 043 3000	201 009 3000

Dimensioned drawings

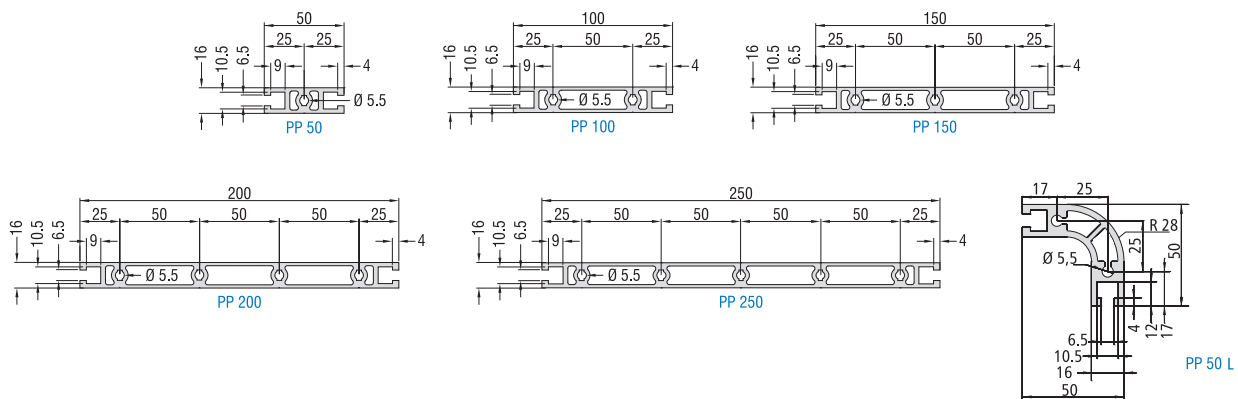

Universal profiles

PU 25/PU 50



Features

- For the fast and simple erection of frames, benches and racks
- Aluminium, naturally anodised
- Produced in accordance with DIN EN 12020-2
- Light, compact & stable
- **For universal use**
- Suitable for very high loads
- The clamping elements and drilled holes of our clamped linkages produce very rigid connections, resistant to tension, distortion and inter-profile bending.
- Profile cutting to order
- Extensive range of accessories (see page 2-14)

Option: - powder coatings
in anthracite and light grey

Technical specification

	PU 25	PU 50
Dimensions (W × H)	25 x 25 mm	50 x 25 mm
Length	up to 3 metres (special lengths upon request)	
Weight	approx. 0.7 kg/m	approx. 1.3 kg/m
	4 T-key inserts for M6 sliding nuts Cavity insert, Ø 5.5 mm for M6	4 T-key inserts for M6 sliding nuts 2 cavity inserts, Ø 5.5 mm for M6
Moment of inertia I_x	1.43 cm ⁴	10.99 cm ⁴
Moment of inertia I_y	1.43 cm ⁴	2.81 cm ⁴
Moment of resistance W_x	1.14 cm ³	4.40 cm ³
Moment of resistance W_y	1.14 cm ³	2.25 cm ³

Ordering data

Profile description	Part no.: L=1000 mm Part no.: L=3000 mm
PU 25 W 25 x H 25 mm	200 001 1000 200 001 3000
PU 50 W 50 x H 25 mm	200 002 1000 200 002 3000

Dimensioned drawings

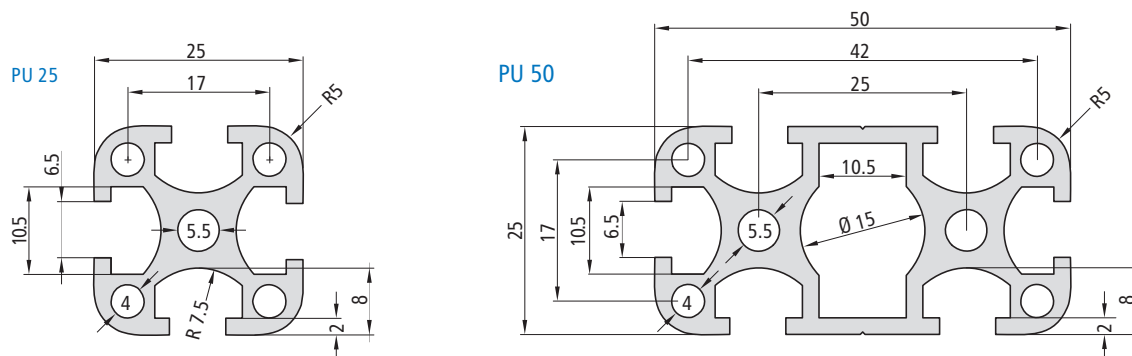

T-slot plates

PT 25



Features

- Universal precision, clamping and machining surface
- Aluminium, naturally anodised
- Produced in accordance with DIN EN 12020-2
- Milled flat on both sides
- For use with any machine
- Thick walled, distortion-free and extremely form-retaining
- Profile cutting to order
- Extensive range of accessories (see page 2-14)
- Option:
 - Drainage channel for small quantities of liquid

Technical specification

	PT 25		
Dimensions (W × H)	125 x 20 mm	250 x 20 mm	375 x 20 mm
Length	up to 3 metres (special lengths upon request)		
Weight	appr. 4.8 kg/m	appr. 9.6 kg/m	appr. 13.7 kg/m
T-slots	one-sided in 25 mm raster		
Moment of inertia I_x	243.36 cm ⁴	1848.57 cm ⁴	5996.01 cm ⁴
Moment of inertia I_y	6.46 cm ⁴	12.77 cm ⁴	17.90 cm ⁴
Moment of resistance W_x	38.94 cm ³	147.88 cm ³	319.79 cm ³
Moment of resistance W_y	6.46 cm ³	12.77 cm ³	17.90 cm ³

Ordering data

L [mm]	PT 25	PT 25	PT 25
	W 125 x H 20 mm	W 250 x H 20 mm	W 375 x H 20 mm
	Part no.	Part no.	Part no.
400	201 014 0400	201 018 0400	201 020 0400
500	201 014 0500	201 018 0500	201 020 0500
600	201 014 0600	201 018 0600	201 020 0600
700	201 014 0700	201 018 0700	201 020 0700
800	201 014 0800	201 018 0800	201 020 0800
900	201 014 0900	201 018 0900	201 020 0900
1000	201 014 1000	201 018 1000	201 020 1000
1100	201 014 1100	201 018 1100	201 020 1100
1200	201 014 1200	201 018 1200	201 020 1200
1300	201 014 1300	201 018 1300	201 020 1300
1400	201 014 1400	201 018 1400	201 020 1400
1500	201 014 1500	201 018 1500	201 020 1500
1800	201 014 1800	201 018 1800	201 020 1800
2000	201 014 2000	201 018 2000	201 020 2000
2500	201 014 2500	201 018 2500	201 020 2500
3000	201 014 3000	201 018 3000	201 020 3000

Dimensioned drawings

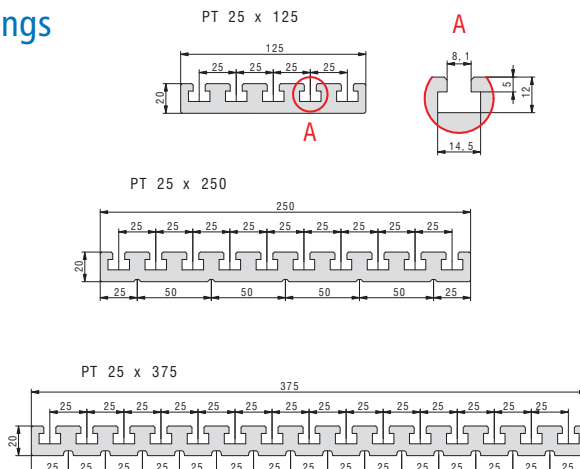

T-nuts - see accessories for aluminium profiles

T-slot plates

PT 50



Features

- Universal precision, clamping and machining surface
- Aluminium, naturally anodised
- Produced in accordance with DIN EN 12020-2
- Milled flat on both sides
- For use with any machine
- Thick walled, distortion-free and extremely form-retaining
- Profile cutting upon request
- Extensive range of accessories (see page 2-14)

Technical specification

	PT 50	
Dimensions (W × H)	250 x 20 mm	375 x 20 mm
Length	up to 3 metres (special lengths upon request)	
Weight	approx. 10.0 kg/m	approx. 14.8 kg/m
T-slots	both-sided in 50 mm raster	
Moment of inertia I_x	2062.99 cm ⁴	6745.96 cm ⁴
Moment of inertia I_y	13.85 cm ⁴	20.63 cm ⁴
Moment of resistance W_x	165.04 cm ³	359.78 cm ³
Moment of resistance W_y	13.85 cm ³	20.63 cm ³

Ordering data

L [mm]	PT 50	PT 50
	W 250 x H 20 mm	W 375 x H 20 mm
	Part no.	Part no.
400	201 016 0400	201 019 0400
500	201 016 0500	201 019 0500
600	201 016 0600	201 019 0600
700	201 016 0700	201 019 0700
800	201 016 0800	201 019 0800
900	201 016 0900	201 019 0900
1000	201 016 1000	201 019 1000
1100	201 016 1100	201 019 1100
1200	201 016 1200	201 019 1200
1300	201 016 1300	201 019 1300
1400	201 016 1400	201 019 1400
1500	201 016 1500	201 019 1500
1800	201 016 1800	201 019 1800
2000	201 016 2000	201 019 2000
2500	201 016 2500	201 019 2500
3000	201 016 3000	201 019 3000

Dimensioned drawings

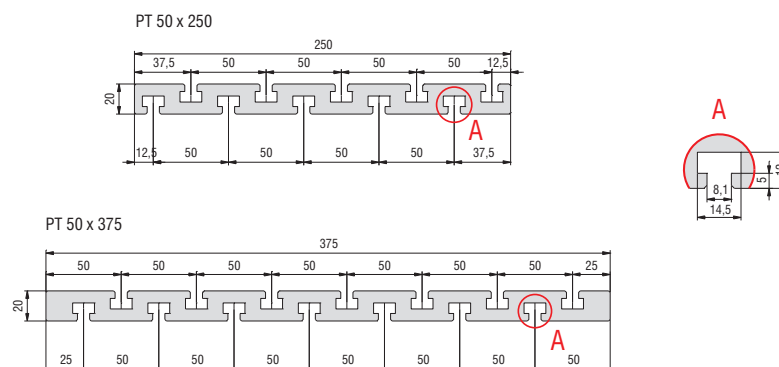

T-nuts - see accessories for aluminium profiles

Rectangular profiles

RE 40



Features

- Universal precision, clamping and machining surface
- As a stabiliser for machine and subframe constructions
- Aluminium, naturally anodised
- Produced in accordance with DIN EN 12020-2
- Light & very stable
- Numerous applications with the accessories are possible
- Profile cutting upon request
- Extensive range of accessories (see page 2-14)

Technical specification

	RE 40		
	150 x 40 mm	250 x 40 mm	350 x 40 mm
Dimensions (W × H)	150 x 40 mm	250 x 40 mm	350 x 40 mm
Length	up to 3 metres (special lengths upon request)		
Weight	approx. 4.8 kg/m	approx. 7.6 kg/m	approx. 13.380 g/m
	various cavities and T-key inserts for sliding nuts or M6 tapped strips for frontal inserts for M6 screws		
Moment of inertia I_x	393.7 cm ⁴	1654.53 cm ⁴	5,626.00 cm ⁴
Moment of inertia I_y	33.42 cm ⁴	54.18 cm ⁴	97.45 cm ⁴
Moment of resistance W_x	52.49 cm ³	131.64 cm ³	321.48 cm ³
Moment of resistance W_y	16.71 cm ³	27.09 cm ³	48.5 cm ³

Ordering data

Profile description	Part no.: L = 1000 mm
	Part no.: L = 3000 mm
RE 40 W 150 x H 40 mm	201 035 1000 201 035 3000
RE 40 W 250 x H 40 mm	201 030 1000 201 030 9000
RE 40 W 350 x H 40 mm	201 031 1000 201 031 3000

Dimensioned drawings

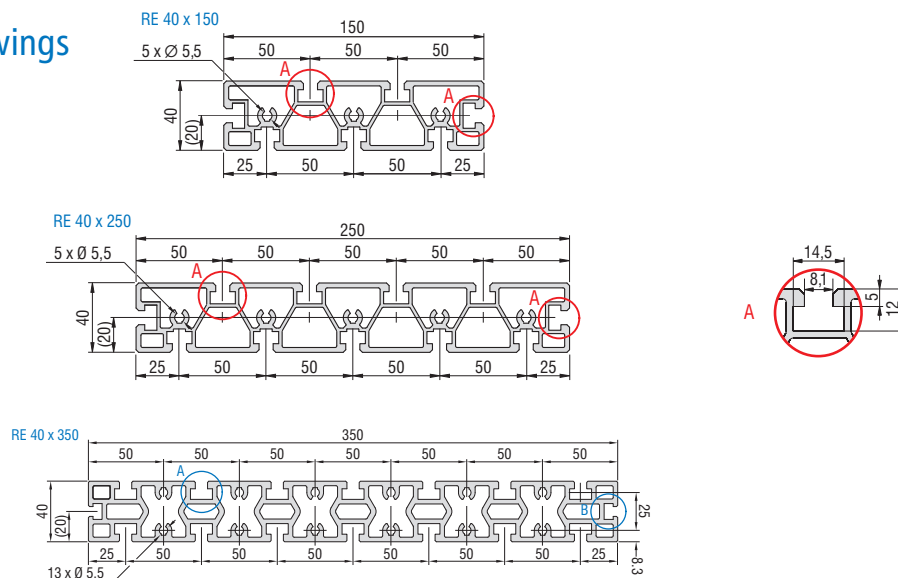

Rectangular profiles

RE 65



Features

- Universal precision, clamping and machining surface
- As a stabiliser for machine and subframe constructions
- Aluminium, naturally anodised
- Produced in accordance with DIN EN 12020-2
- Light & very stable
- Milled flat on both sides
- Numerous applications with the accessories are possible
- Profile cutting upon request
- Extensive range of accessories (see page 2-14)

Technical specification

	RE 65	
Dimensions (W × H)	150 x 65 mm	250 x 65 mm
Length	up to 3 metres (special lengths to order)	
Weight	approx. 7.7 kg/m	approx. 12.4 kg/m
	various cavities and T-key inserts for sliding nuts or M6 tapped strips for frontal inserts for M6 screws	
Moment of inertia I_x	633.47 cm ⁴	2,658.48 cm ⁴
Moment of inertia I_y	148.87 cm ⁴	243.85 cm ⁴
Moment of resistance W_x	84.46 cm ³	212.68 cm ³
Moment of resistance W_y	45.83 cm ³	75.03 cm ³

Ordering data

Profile description	Part no.: L=1000 mm Part no.: L=3000 mm
RE 65 W 150 x H 65 mm	201 034 1000 201 034 3000
RE 65 W 250 x H 65 mm	201 032 1000 201 032 3000

Dimensioned drawings

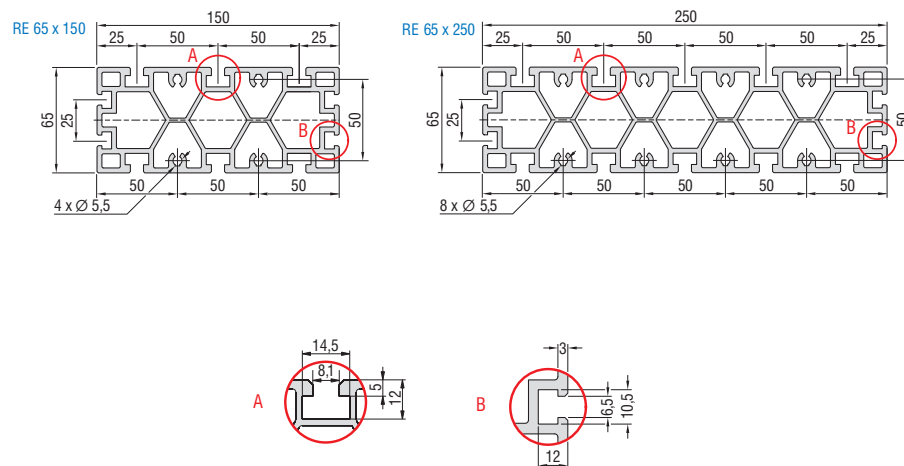

Light frame profiles

PL 40/PL 80



Features

- For the fast and simple erection of frames, benches and racks
- Aluminium, naturally anodised
- Produced in accordance with DIN EN 12020-2
- Light, compact & stable
- Suitable for very high loads
- The clamping elements and drilled holes of our clamped linkages produce very rigid connections, resistant to tension, distortion and bending between the profiles.
- Profile cutting upon request
- Extensive range of accessories (see page 2-14)

Option: - powder coatings
in anthracite and light grey

Technical specification

	PL 40	PL 80
Dimensions (W × H)	40 x 40 mm	80 x 40 mm
Length	up to 3 metres (special lengths to order)	
Weight	approx. 1.5 kg/m	approx. 2.9 kg/m
	4 T-key inserts for M6 sliding nuts 5 cavity inserts, Ø 8.5 mm for M10	6 T-key inserts for M6 sliding nuts 6 cavity inserts, Ø 8.5 mm for M10 Cavity insert, Ø 10.2 mm for M12
Moment of inertia I_x	8.38 cm ⁴	64.40 cm ⁴
Moment of inertia I_y	8.38 cm ⁴	16.36 cm ⁴
Moment of resistance W_x	4.19 cm ³	16.10 cm ³
Moment of resistance W_y	4.19 cm ³	8.18 cm ³

Ordering data

Profile description	Part no.: L=1000 mm
	Part no.: L=3000 mm
PL 40 W 40 x H 40 mm	200 008 1000 200 008 3000
PL 80 W 80 x H 40 mm	200 009 1000 200 009 3000

Dimensioned drawings

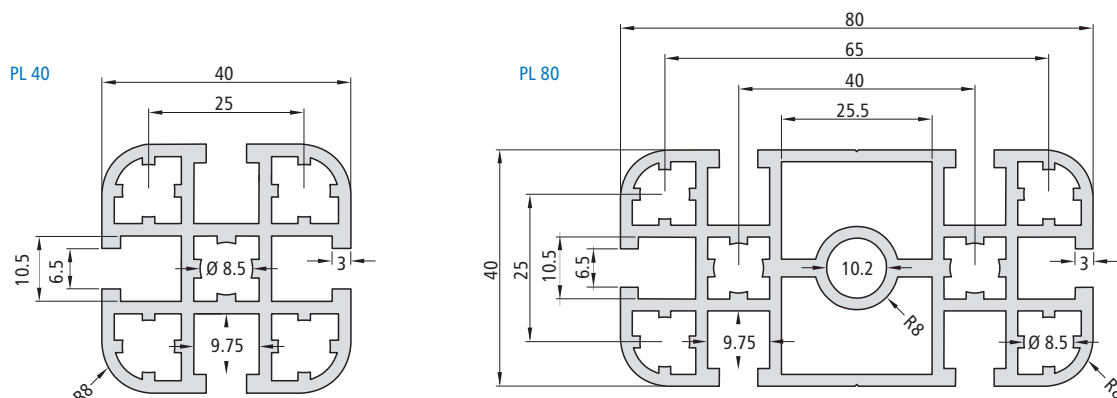

Stand profiles

PS 50/PS 80



Features

- For the fast and simple erection of frames, benches and racks
- Aluminium, naturally anodised
- Produced in accordance with DIN EN 12020-2
- Light, compact & stable
- Suitable for high loads
- Our clamped linkages produce very rigid connections, resistant to tension, distortion and bending, between profiles
- Profile cutting upon request
- Extensive range of accessories (see page 2-14)

Option: - powder coatings
in anthracite and light grey

Technical specification

	PS 50	PS 80
Dimensions (W × H)	50 x 50 mm	80 x 80 mm
Length	up to 3 metres (special lengths upon request)	
Weight	approx. 2.3 kg/m	approx. 4.5 kg/m
	4 T-key inserts for M6 sliding nuts 4 cavity inserts, Ø 5.5 mm for M6 Cavity insert, Ø 8.5 mm for M10	4 T-key inserts for M6 sliding nuts 4 cavity inserts, Ø 5.5 mm for M6 Cavity insert, Ø 10.2 mm for M12
Moment of inertia I_x	22.06 cm ⁴	111.8 cm ⁴
Moment of inertia I_y	22.06 cm ⁴	111.8 cm ⁴
Moment of resistance W_x	8.82 cm ³	27.95 cm ³
Moment of resistance W_y	8.82 cm ³	27.95 cm ³

Ordering data

Profile description	Part no.: L=1000 mm
	Part no.: L=3000 mm
PS 50 W 50 x H 50 mm	200 003 1000 200 003 3000
PS 80 W 80 x H 80 mm	200 014 1000 200 014 3000

Dimensioned drawings

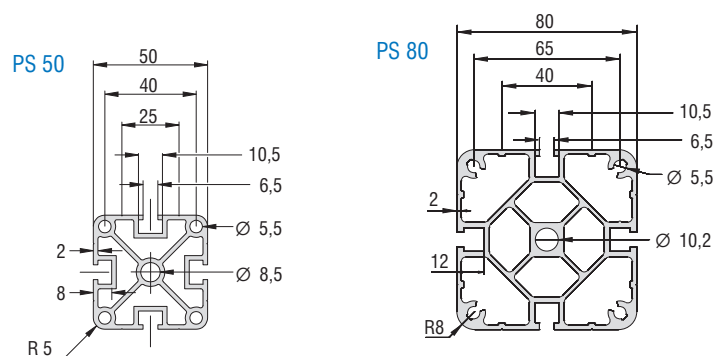

Stand profiles

PS100



Features

- For fast and easy erection of frames, benches and racks
- Aluminium, naturally anodised
- Produced in accordance with DIN EN 12020-2
- Light, compact & stable
- Suitable for high loads
- Our clamped linkages produce very rigid connections, resistant to tension, distortion and bending, between profiles
- Profile cutting upon request
- Extensive range of accessories (see page 2-14)

Option: - powder coatings
in anthracite and light grey

Technical specification

	PS 100
Dimensions (W × H)	100 x 100 mm
Length	up to 3 metres (special lengths to order)
Weight	approx. 5.1 kg/m
	4 T-key inserts for M6 sliding nuts 4 cavity inserts, Ø 5.55 mm for M6 Cavity insert, Ø 10.2 mm for M12
Moment of inertia I_x	163.00 cm ⁴
Moment of inertia I_y	163.00 cm ⁴
Moment of resistance W_x	32.60 cm ³
Moment of resistance W_y	32.60 cm ³

Ordering data

Profile description	Part no.: L=1000 mm Part no.: L=3000 mm
PS 100	200 015 1000
W 100 x H 100 mm	200 015 3000

Dimensioned drawings

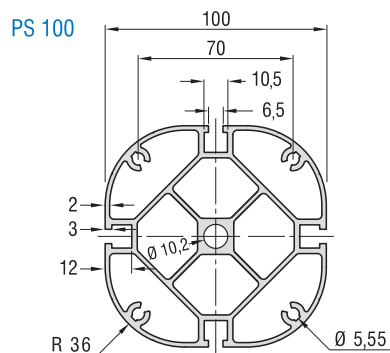

Workbenches

AT

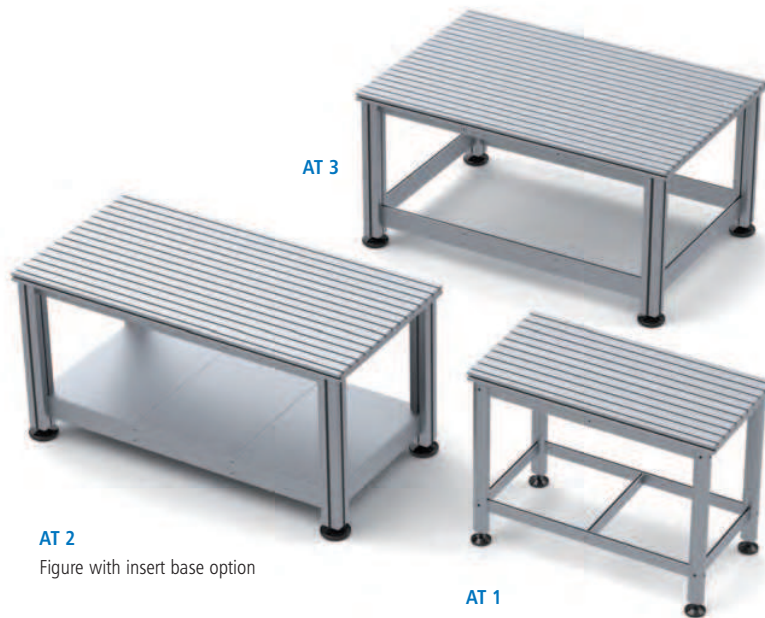

AT 2
Figure with insert base option

AT 1

AT 3

Features

Workbenches AT for clamping devices, clamping means, for measurement, checking, testing, etc.

- Sub-frame from aluminium profiles PS series with braces made from aluminium panel profiles PP series
- Aluminium bench plate RE series of rectangular profiles 40 × 250 mm with T-slots

Options

- Length up to 2 m
- Various accessories

Accessories

Insert base for AT 1
Part no.: **248551 0010**

Insert base for AT 2
Part no.: **248551 0012**

Insert base for AT 3
Part no.: **248551 0013**

Ordering data

Part no.	Description	Load: Surface load	Weight	suitable for
248 550 0010	AT 1, W 1000 x D 500 x H 750 mm	200 kg	approx. 30 kg	
248 550 0012	AT 2, W 1500 x D 750 x H 750 mm	400 kg	approx. 60 kg	ICP 3020
248 550 0013	AT 3, W 1500 x D 1000 x H 750 mm	400 kg	approx. 75 kg	ICP/ICV 4030

Dimensioned drawings

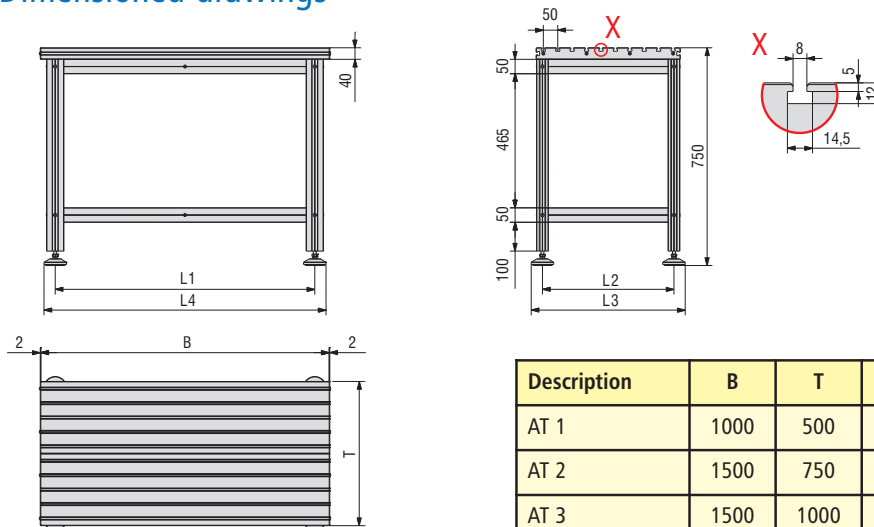

Description	B	T	L 1	L 2	L 3	L 4
AT 1	1000	500	900	456	536	980
AT 2	1500	750	1380	660	780	1500
AT 3	1500	1000	1380	910	1030	1500

Accessories

Tapped rails



M6 tapped rail

- 13 x 6 mm
- Galvanised
- M6 Ra 50 mm
- VE 3 units at 1 m
- For PT/RE 40, 65

Part no.: 209010

M6 tapped rail

- 10 x 4 mm
- Galvanised
- M6 Ra 50 mm
- VE 3 units at 1 m
- For all except PT/RE 40, 65/SP

Part no.: 209011

Sliding nuts



M6 sliding nut (Figure 1)

- L25 x W10 x H3.5
- Galvanised
- VE 100 units
- All except PT/RE 40, 65

Part no.: 209001 0005

M6 sliding nut (Figure 1)

- L 25 x W 13 x H 5
- Galvanised
- VE 50 units
- For PT/RE 40, 65

Part no.: 209004 0001

2 x M6 sliding nuts (Figure 2)

- L45 x W10 x H3.5
- Galvanised
- VE 50 units
- For all except PT/RE 40, 65

Part no.: 209002 0004

2 x M6 sliding nuts (Figure 2)

- L 45 x W 13 x H 6
- Galvanised
- 2xM6 Ra 25mm
- VE 25 units
- For PT/RE 40, 65

Part no.: 209005 0001

M5 sliding nut

- L25 x W10 x H3.5
- Galvanised
- VE 20 units
- For all except PT/RE 40, 65

Part no.: 209006 0001

Angle sliding nut

2 x M6 (Figure 3)

- Galvanised
- VE 25 units
- For all except PT/RE 40, 65

Part no.: 209021 0003

Special angle sliding nut

3 x M6 (Figure 4)

- Galvanised
- VE 25 units
- For all except PT/RE 40, 65

Part no.: 209022 0003

Sliding nuts

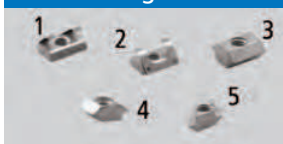

M5/M6 sliding nuts

- Galvanised
- VE 20 units
- for PT25, PT 50, PS 200, RE 40 and RE 65 (securing only possible at the top) with spring

Part no.: 209005 0002 (M5/Figure 1)

Part no.: 209005 0003 (M6/Figure 2) with large chamfer

Part no.: 209005 0004 (M6/Figure 3) in rhombus shape

Part no.: 209005 0005 (M5/Figure 4)

Part no.: 209005 0006 (M6/Figure 5)

Tension rods



Tension rods SE

- With M6 setting screw
- VE 2 units
- For RE/PT

Part no.: 290051

Clamping devices



Hand lever clamping device

SH 1

- for RE/PT

Part no.: 290001

Hand lever clamping device

SH 2

- For RE/PT

Part no.: 290002

Stop rails



Stop rail (galvanised)

- W 20 x H 10
- Ra 50
- VE 2 units + fixing material

L 125 mm

Part no.: 290021 0125

L 175 mm

Part no.: 290021 0175

L 225 mm

Part no.: 290021 0225

T-keys



M6 T-keyways

- DIN 508
- Hardened
- VE 20 units
- For PT/RE 40, 65

Part no.: 209119 0003

Edging strip



Black edging strip 1-part

- For plate thicknesses 3 - 4 mm
- VE 10 m

Part no.: 209202 0002 (PU profiles)

Part no.: 209202 0001

(PP-/RE- and PS profiles)

PP 50 cross-braces



PP 50 cross-braces

- L 490 mm
- Mitred
- M6 drillings
- for all except PT/RE 40, 65

Part no.: 209300 0000

Hinge strip



Plastic hinge strip

- L 65 x W 40
- VE 10 units + fixing
- Ra 43 x 20 mm
- For PL

Part no.: 209050 0012

Aluminium hinge strip

- L 40 x W 40 mm
- VE 10 units + fixing
- Ra 25 x 25 mm
- For all except PT/RE 40, 65

Part no.: 209050 0011

Accessories

Profile connection cubes



Profile connection cubes black

- VE 10 units + fixing material
- For PU 25

2 x Part no.: **209104 0002**

Part no.: Part no.: **209103 0002**



Profile connection cubes, black

- VE 10 units + fixing material
- For PU 25

Part no.: Part no.: **209106 0002**

Part no.: Part no.: **209107 0002**



Profile connection cubes black

- VE 10 units + fixing material
- For PU 25

Four-fold Part no.: **209108 0002**

Five-fold Part no.: **209109 0002**

T-slot cover



T-slot cover

- VE 30 m
- (turquoise = similar to RAL 5018)
- For all except PT/RE 40, 65

black Part no.: **209201 0004**

turquoise Part no.: **209201 0003**

light grey Part no.: **209201 0007**

Profile covers



Profile covers, black

- PU 25 - 25 units
Part no.: **209105 0003**
- PU 50 - 25 units
Part no.: **209126 0003**
- PL 40 - 20 units
Part no.: **209127 0003**
- PL 80 - 20 units
Part no.: **209128 0003**
- PS 50 - 25 units
Part no.: **209129 0003**
- PS 80 - 20 units
Part no.: **209130 0003**
- PS 140 - 10 units
Part no.: **209130 1001**

Aluminium corner connector



Aluminium corner connector

- L 25 × W 25 × H 15 mm
- VE 10 units + fixing material
- For PL, PS, PU, PP

natural
Part no.: **209114 0101**

black
Part no.: **209114 0111**

- L 40 × W 40 × H 22 mm
- VE 10 units + fixing material
- For PP/PL/PS/PU

natural
Part no.: **209115 0101**

black
Part no.: **209115 0111**

- L 50 × W 50 × H 15
- VE 10 units + fixing material
- For RE/PU/PS

natural
Part no.: **209116 0101**

black
Part no.: **209116 0111**

- L 80 × W 80 × H 22
- VE 10 units + fixing material
- For PP/PL/PS/PU

natural
Part no.: **209117 0101**

black
Part no.: **209117 0111**

Plastic equipment bases



Plastic equipment bases with rubber plate

- VE 4 units + setting screws
- Black

For PL 40/PS 50

- Ø 60
 - M10 × 50 setting screws
- Part no.: **209032 0003**

for PL 80 / PS 80

- Ø 80
 - M12 × 50 setting screws
- Part no.: **209034 0001**

for PL 80 / PS 80

- Ø 120
 - Setting screws M12 × 50
 - Black
- Part no.: **209033 0003**

Guide rollers



Rubber-tired guide rollers Ø 75 (M10)

- VE 4 units
- 2 with and 2 without locking device
- for PL 40/PS 50

Part no.: **209043 0011**

Aluminium equipment bases



Aluminium equipment bases with rubber plate

- for PU 50
- VE 4 units, with setting screws and reducing bushings
 - Ø 50
 - M6 × 30 setting screws
 - Natural
- Part no.: **209030 0000**

for PS 100/140

- Ø 170
 - M16 × 100 setting screws
 - Black
- Part no.: **209035 0001**

Profile connections

Examples:

PS 50 with PU 50

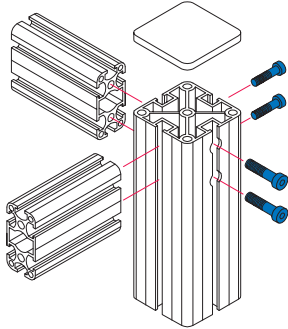

PS 50 with PP 250

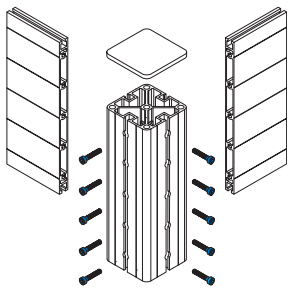

PS 80 with PL 80

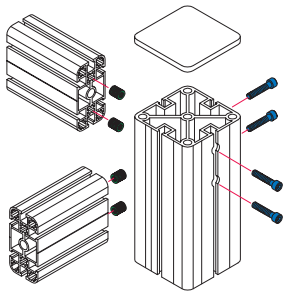

Allen screws

Allen screws
M6 × 25 mm

- VE 10 units
Part no.: **209147 0009**
- VE 50 units
Part no.: **209147 0010**

Allen screws
M6 x 50 mm

- VE 10 units
Part no.: **209147 0003**
- VE 50 units
Part no.: **209147 0004**

Allen key
SW 5

- DIN 911
- VE 1 unit
Part no.: **931152**

Tapped bushings

Tapped bushings
M9/M6

- VE 10 units
Part no.: **209147 0001**
- VE 50 units
Part no.: **209147 0002**

Tapped bushings
M10/M6

- VE 10 units
Part no.: **209147 0124**
- VE 50 units
Part no.: **209147 0125**

Example PL 80

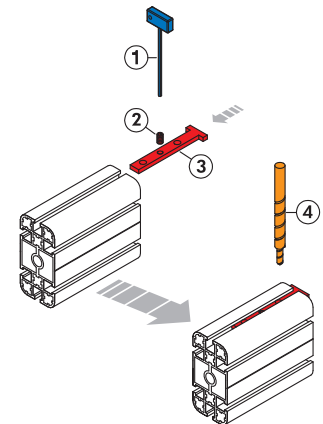

- ① Hexagon-socket Screwdriver
- ② Grub Screw
- ③ Drilling Template
- ④ Twist Drill
Ø 6 mm / Ø 10.4 mm

Example:

Profile snaplock extension for PS 50

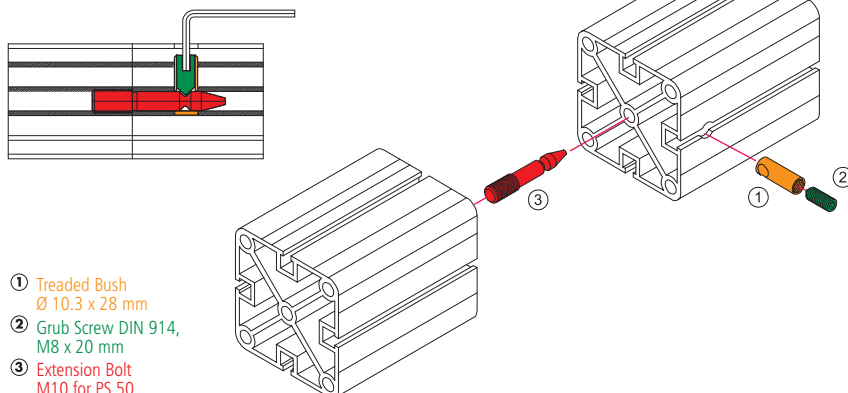

- ① Treaded Bush
Ø 10.3 x 28 mm
- ② Grub Screw DIN 914,
M8 x 20 mm
- ③ Extension Bolt
M10 for PS 50

for PS 50/PL 40 (M10)

- Locking bush, tapped pin, extension bolts
- Part no.: **209147 0120**
- 50 sets
Part no.: **209147 0121**

for PS 80/PL 80 (M12)

- Locking bush, tapped pin, extension bolts
- 10 sets
Part no.: **209147 0122**
- 50 sets
Part no.: **209147 0123**

matching drill pattern 2
Part no.: **290015 0002**

Stepped drill

- Ø 6/Ø 10.4 mm
Part no.: **400090**

Profile snaplock connections

Example:
PL with PS 80

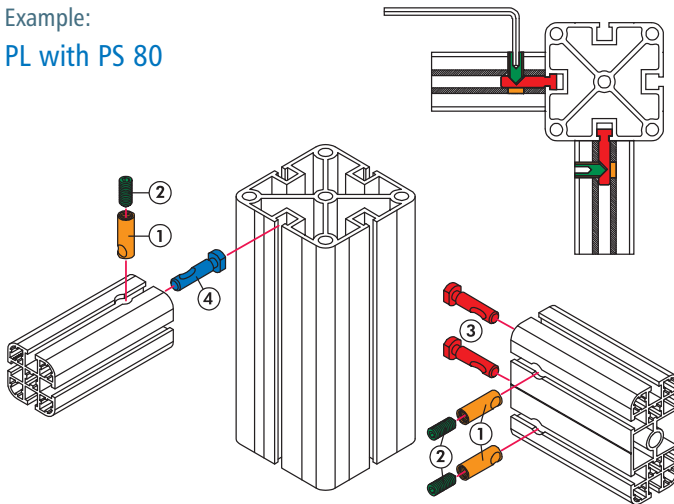

- ① Treaded Bush \varnothing 10.3 x 28 mm
- ② Grub Screw DIN 914, M6 x 20 mm
- ③ Connection Bolt 0° for PL 40 and PL 80
- ④ Connection Bolt 90° for PL 40 and PL 80

Snaplock
connection
0 degrees

e.g. for
PL / PS 80

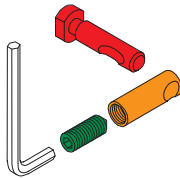

Snaplock
connection
90 degrees

e.g. for
PP / PU / PS

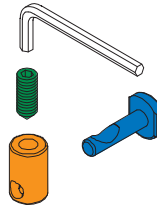

Snaplock connection

for PL

- Locking bush, tapped pin and bolts 0°
- 10 sets:
Part no.: **209147 0102**
- 50 sets:
Part no.: **209147 0103**

for PL

- Locking bush, tapped pin and bolts 90°
- 10 sets:
Part no.: **209147 0112**
- 50 sets:
Part no.: **209147 0113**

for PP/PU

- Locking bush, tapped pin and bolts 0°
- 10 sets:
Part no.: **209147 0100**
- 50 sets:
Part no.: **209147 0101**

for PP/PU

- Locking bush, tapped pin and bolts 90°
- 10 sets:
Part no.: **209147 0110**
- 50 sets:
Part no.: **209147 0111**

Example:
PP with PS 50

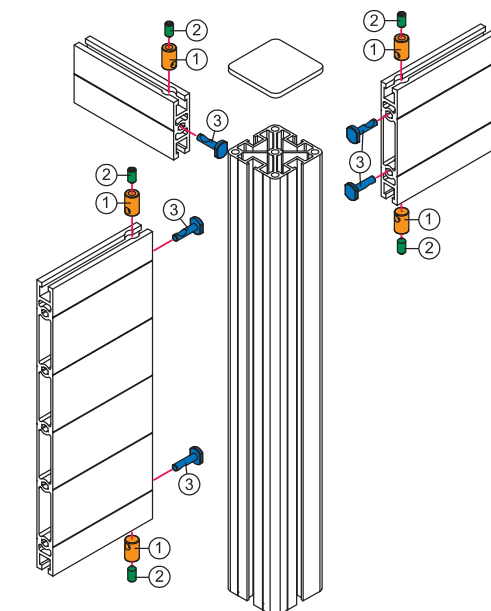

- ① Treaded Bush \varnothing 10.3 x 16,5 mm
- ② Grub Screw DIN 914, M6 x 12 mm
- ③ Connection Bolt 90°

Stepped drill

- \varnothing 6 mm/ \varnothing 10.4 mm
- Part no.: **400090**

matching drill pattern 2

Part no.: **290015 0002**

Allen key

SW 3

- DIN 911
- Part no.: **931150**